

Ruby Electric Towel Dry Installation and User Manual



-Keep your life warm-

## Please Read This Manual First!

Our dear customer,

Thank you for choosing the Radyal Electric product. We want our product, which is produced with high quality and technology, to offer you the best efficiency. For this purpose, before using the product, carefully read the entire manual and other documents provided and keep them for future reference. If you give the product to someone else, also provide the user manual with it. Heed all warnings and information contained in the user manual.

### Contents;

1. Important safety precautions
2. Display of parts
3. Product images
4. Assembly instructions
5. Operation
6. Cleaning and maintenance instructions

## 1. Important safety precautions

- When using electrical appliances, to reduce the risk of fire, electric shock and injury, one should always follow the basic precautions, which include: Read all instructions before using the product.
- This product is hot during use. To avoid burns, do not let your bare skin come into contact with hot surfaces.
- Extreme care should be taken when the product is used near children and leaving it unattended.
- If special precautions need to be taken during the installation of the device, appropriate details should be given.
- If the supply cord is damaged, it must be replaced by Radyal Technical Service or services authorized by Radyal in order to avoid a dangerous situation.
- Do not use the product outdoors. This product is designed for indoor use only.
- Do not route the power cord under the carpet and do not cover the cord with rugs, runners, etc.
- Route the power cord through places where people do not pass or trip over.
- To disconnect, turn all controls to the 'off' position, then unplug the power plug from the outlet.
- Do not use the product in greenhouses and construction sites.
- Use the product only as specified in this manual. Using the device other than the manufacturer's instructions may result in fire, electric shock, or personal injury.
- The radiator should not be placed directly below an electrical outlet.
- In order to avoid any hazard, if the power cord is damaged, it must be replaced by the manufacturer, the manufacturer's service centre or a similarly licensed person.

**Warning:** The product needs to be restarted after power cuts.

- This appliance can be used by children aged 8 years and above and persons with reduced physical, sensory or mental capabilities or lack of experience and knowledge if they have been given supervision or instructions about its safe use and understand the hazards involved. Children should not play with the device. Cleaning and user care should not be carried out by unattended children.

### - Proper disposal of this product



This marking indicates that this product should not be disposed of with other household waste in EU countries. To prevent potential harm to the environment or human health from uncontrolled waste disposal, recycle the product responsibly to support the sustainable reuse of material resources. To recycle your used device, please use the recycling or collection systems or consult the retailer where you purchased the product. They can take the product from you for environmentally safe recycling.

- This product is a dry type heater, it does not contain any liquid.
- Children under the age of 3 should be kept away from the product unless they are under constant supervision. Children aged 3 to 8 years may only switch the appliance on or off when it's placed or installed in its normal operating position if they have been given supervision or instruction concerning use of the appliance in a safe way and understand the hazards involved. Children between the ages 3 and 8 should not plug the device into the socket, and should not make adjustments, cleaning or user maintenance on the device.



**Warning:** some parts of this product may overheat and cause burns. It is necessary to pay special attention to environments where there are children or people who need to be supervised.

## 2. Assembly display of parts

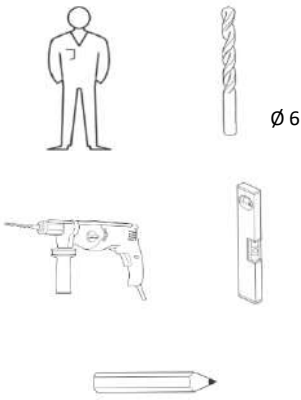

MODEL						
Ruby TW 1080	2	2	2	2	1	1
Ruby TW 1150	3	3	3	3	1	1
Ruby TW 2020	3	3	3	3	1	1
Ruby TW 2080	5	5	5	5	1	1
Ruby TW 2150	6	6	6	6	1	1
Ruby TW 3020	3	3	3	3	1	1
Ruby TW 3080	3	3	3	3	1	1
Ruby TW 3150	5	5	5	5	1	1
Ruby TW 3150-1	6	6	6	6	1	1
Ruby TW 4040	3	3	3	3	1	1
Ruby TW 4080	3	3	3	3	1	1

## 3. Product images

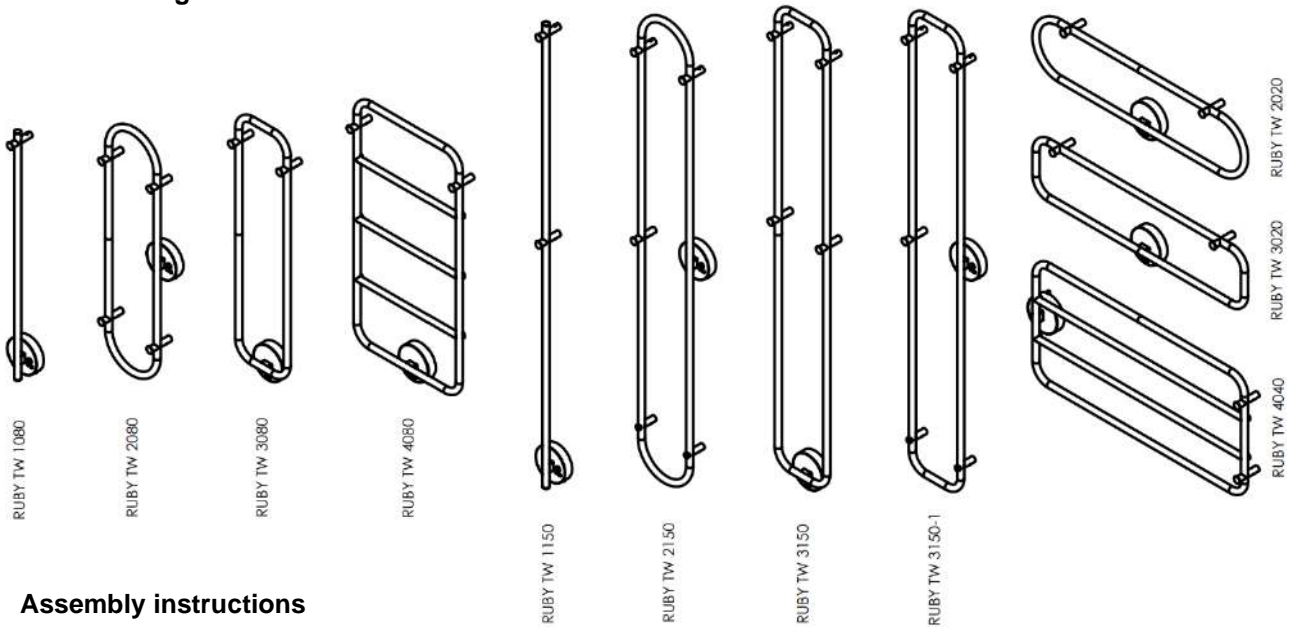

## 4. Assembly instructions

Model	Voltage	Power	IP Protection Class	Certificate	h1(mm)	h2(mm)	a1(mm)	a2(mm)
Ruby TW 1080	220V	14 Watt	IP 45	CE	739,8			28,2
Ruby TW 1150	220V	29 Watt	IP 45	CE	670	769,8		28,2
Ruby TW 2020	220V	30 Watt	IP 45	CE	227,2	292,8	181	28,2
Ruby TW 2080	220V	30 Watt	IP 45	CE	292,8	227,2	181	28,2
Ruby TW 2150	220V	52 Watt	IP 45	CE	642,8	577,2	181	28,2
Ruby TW 3020	220V	30 Watt	IP 45	CE	267,2	333,3	181	28,2
Ruby TW 3080	220V	30 Watt	IP 45	CE	719,2		181	57,7
Ruby TW 3150	220V	52 Watt	IP 45	CE	600	819,2	181	57,7
Ruby TW 3150-1	220V	52 Watt	IP 45	CE	683,3	617,7	181	28,2
Ruby TW 4040	220V	78 Watt	IP 45	CE	781	87,2	240	28,2
Ruby TW 4080	220V	68 Watt	IP 45	CE	719,2		381	157,7

1- The h1 and h2 values the distance between the center of the Hanger Apparatus.

2- a1 value shows the distance between two Panel axes.

3 -a2 value indicates the distance between the center of the Hanger Bracket of the Box and the axis of the Panel.

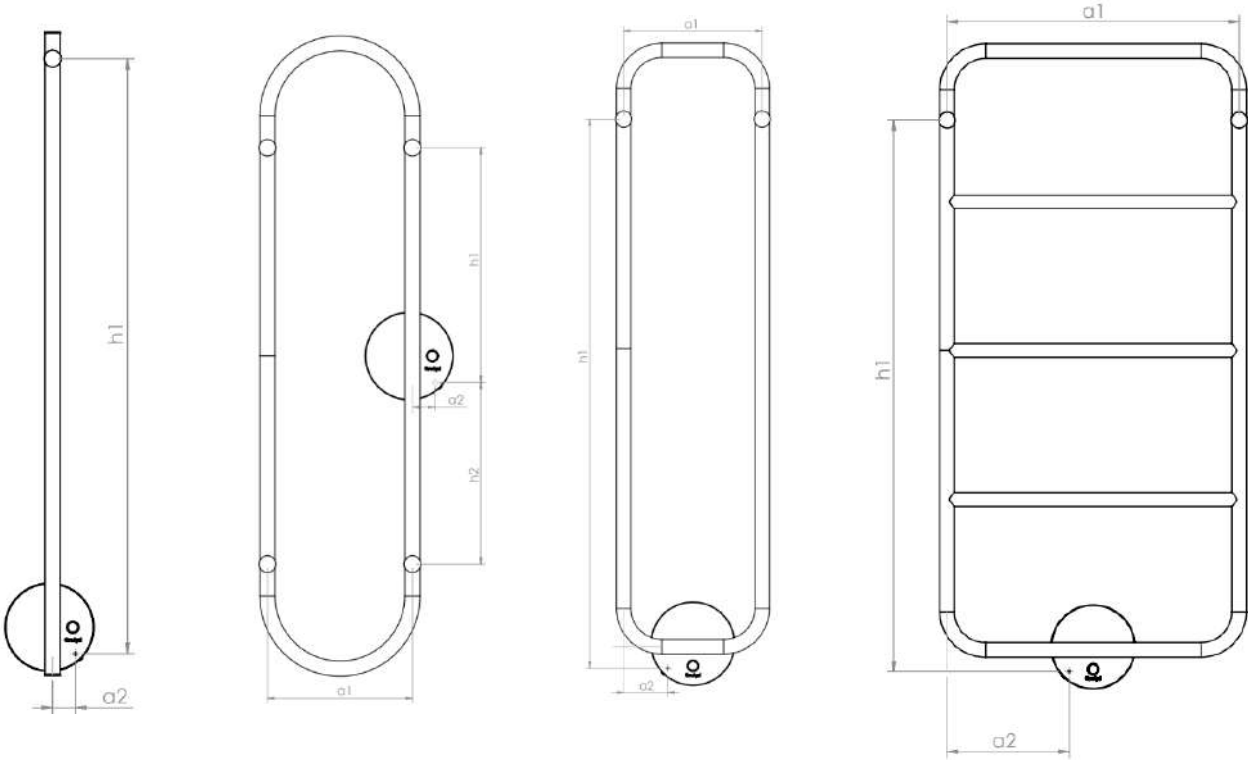

RUBY  
TW 1080

RUBY  
TW 2080

RUBY  
TW 3080

RUBY  
TW 4080

RUBY  
TW 2020

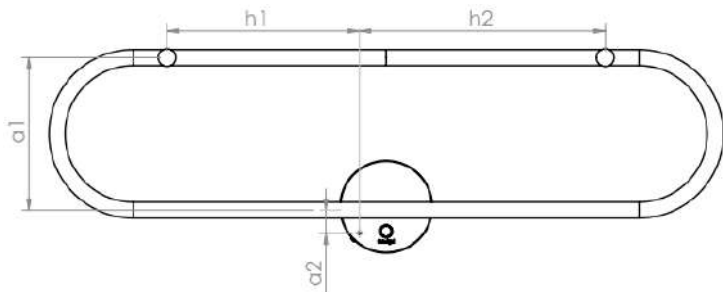

RUBY  
TW 3020

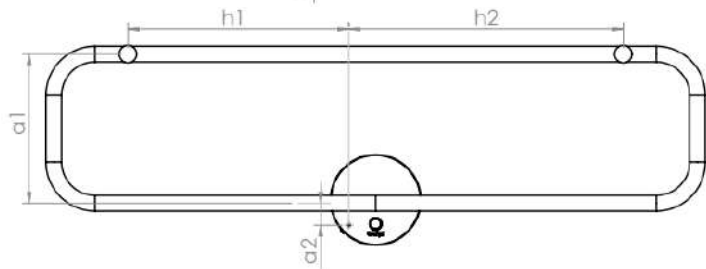

RUBY  
TW 4040

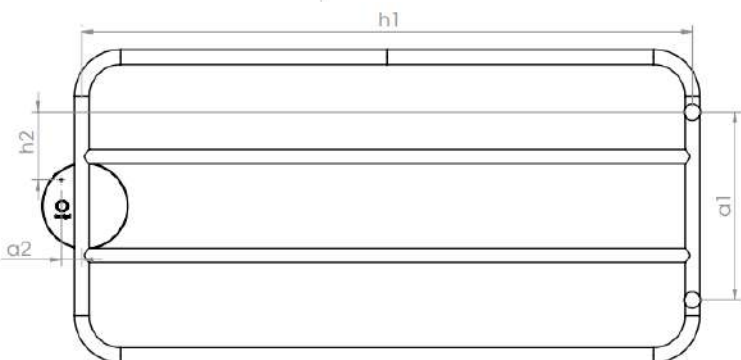

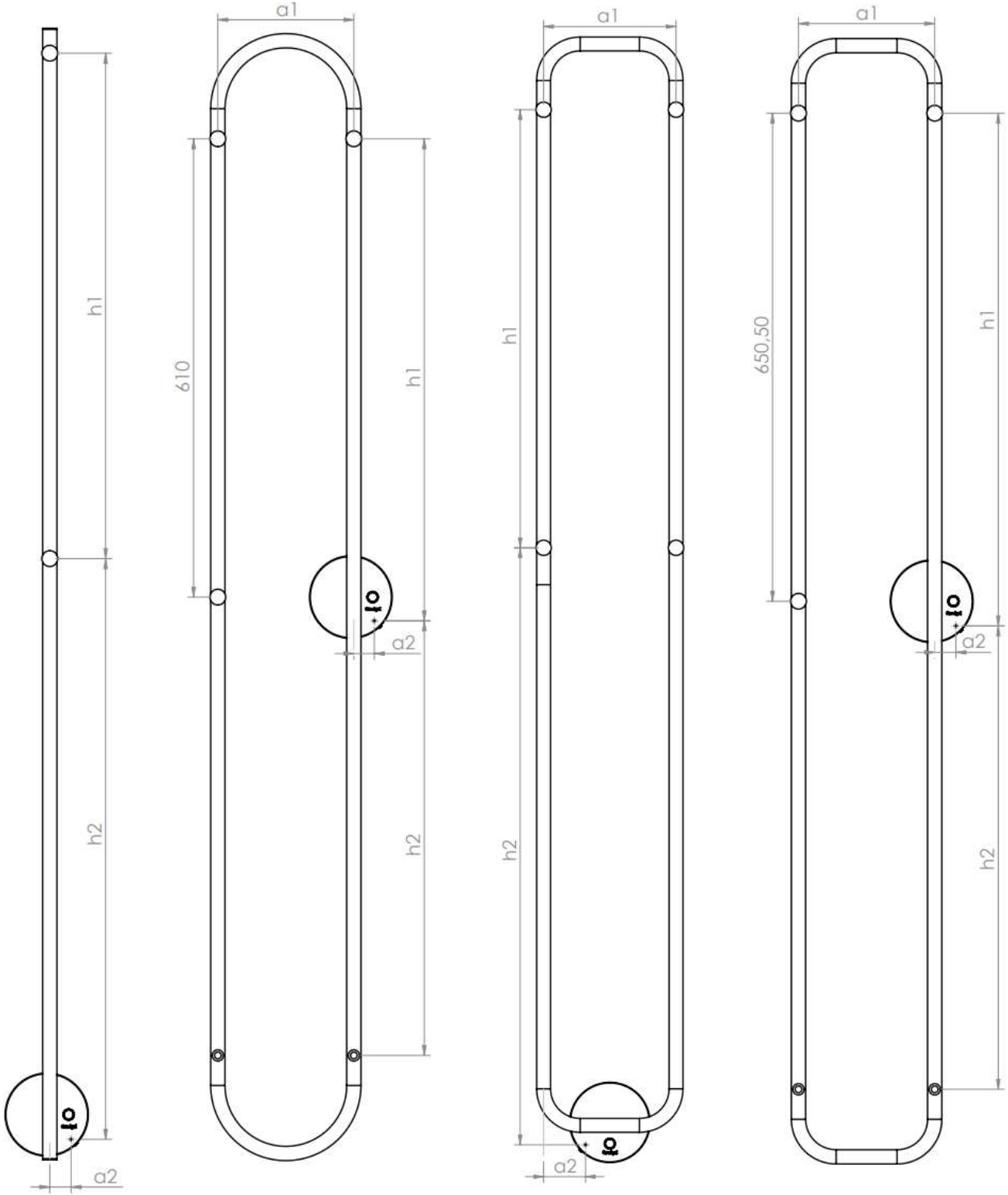

RUBY  
TW 1150

RUBY  
TW 2150

RUBY  
TW 3150

RUBY TW  
3150-1

## Fixing the product to the wall

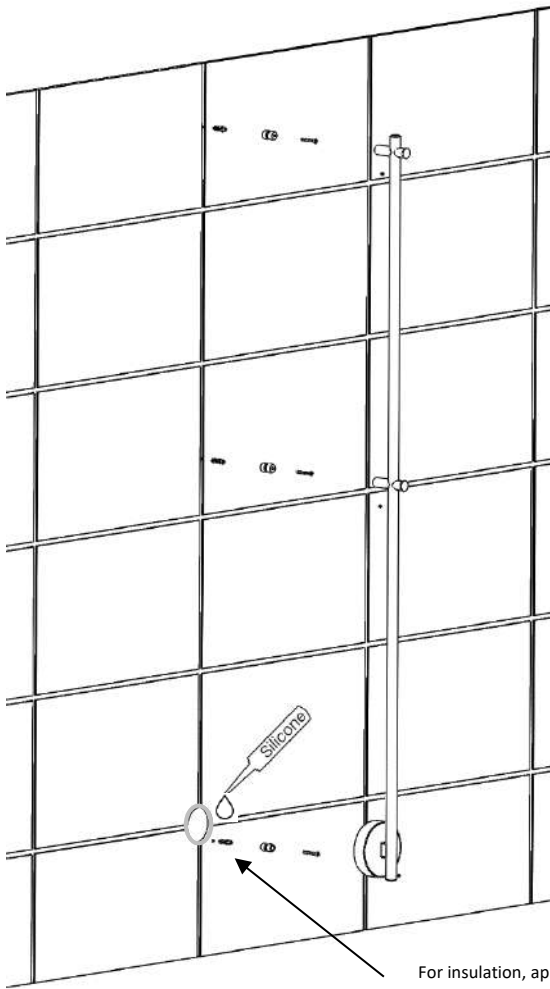

For insulation, apply silicone around the Box.

For mounting, use the 1:1 size Wall Mounting Paper that came in the Box.

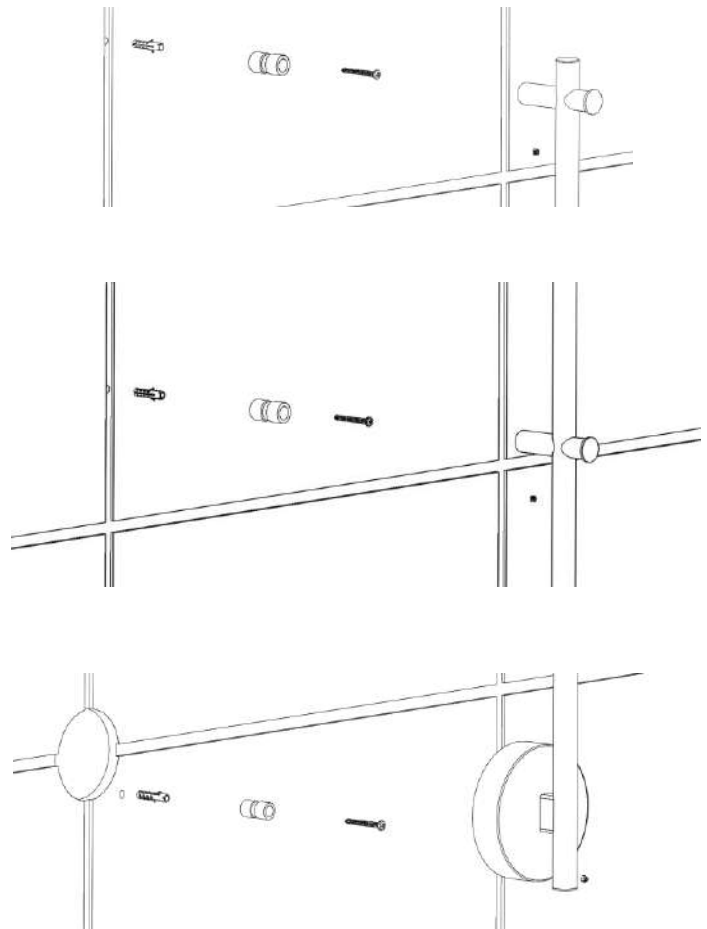

## 5. Operation

The electrical connection of the product is securely

Once done, you can run it by pressing the button.

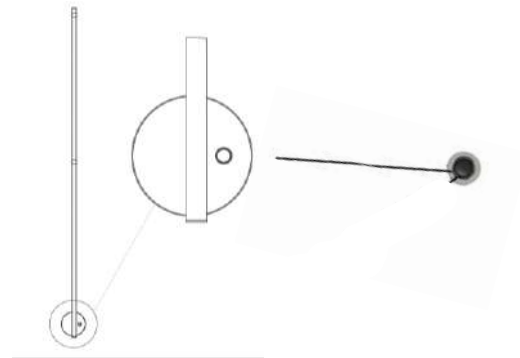

**Program 1-** When the button is pressed once, a white light turns on around the button and the towel dry works indefinitely.

**Program 2-** When the button is pressed a second time; the light decreases by one level, the towel dry continues to operate and automatically turns off after two hours.

**Program 3-** When the button is pressed for the third time; the light will decrease by one more level, the towel dry will continue to operate and will automatically turn off after four hours. When the button is pressed again, the program continues from 1 again.

**Shutdown -** Regardless of which program the device is in, when the button is pressed for 1.5 seconds, the device turns off.

## 6. Cleaning and maintenance instructions

1. Electric Towel dry should be cleaned regularly to remove dust on it. Regular cleaning can affect the radiator heat dissipation efficiency.
2. Unplug it and leave the towel dry to cool. Then wipe off the dust with a damp and soft cloth. Do not use detergents or abrasive products.
3. Be careful not to scratch the surface of the towel dry with hard and sharp tools. Otherwise, you can damage the paint layer.

### We kindly ask you to follow the suggestions below.

1. When you purchase your product, have your authorized seller confirm the warranty certificate.
2. Use your product according to the principles of the user manual.
3. When you have a service request regarding your product, please contact our Technical Service at the above phone numbers.
4. Do not forget to ask for a copy of the "technical service form" after the technical service technician provides service to you.

### Customer Satisfaction Policy

As Radyal Isitma Sistemleri Inc., we adopt a customer-oriented approach with the main principle of providing an excellent customer experience, where customer requests and suggestions of our brand we serve can be easily conveyed through every channel (phone, social media, letter, e-mail, dealer) regardless of customer profile; are collected in a single traceable, reportable, transparent and secure information pool, in which their records are handled in accordance with legal regulations, objectively, fairly and confidentially.

In parallel with our approach, all processes are integrated with the management system, a structure that controls each other has been developed, and management goals are also fed through this system.

### Customer Considerations Regarding Warranty

This warranty provided by Radyal does not cover the malfunctions caused by the use of the Electric Towel dry outside the normal range, also the following situations are excluded from the warranty:

1. Damage and malfunctions caused by usage errors,
2. Damage and malfunctions that occur during loading, unloading and transportation after the delivery of the product to the customer,
3. Voltage drop or excess; faulty electrical wiring; damage and malfunctions caused by using the product at a voltage different than the voltage written on the label,
4. Failures and damage that may occur due to fire or lightning strikes,
5. Malfunctions caused by the use of the product contrary to the considerations contained in the user manuals.

The warranty given to the product will expire if the product is interfered with by unauthorized persons.

Repair of the above-mentioned faults is done for a fee.

Installation and transportation of the product to the place of use is not included in the product price.

The responsibility for issuing the warranty certificate to the consumer by updating it belongs to the seller, dealer, agent or representative offices where the consumer buys the product. This warranty is invalid if the warranty card has been tampered with, the original serial number on the product has been removed or has been tampered with.



## WARRANTY TERMS

- 1) The warranty period starts from the delivery date of the goods and is 2 years.
- 2) Provided that the product is used as shown in the introduction and user manual and has not been interfered with for maintenance, repair or any other reason by persons other than the service personnel authorized by Radyal, the entirety of the goods, including all its parts; guarantees against material, workmanship and manufacturing defects for the period specified above from the date of delivery of the goods.
- 3) In case of understanding that the goods are defective, the consumer is obliged to comply with the requirements set out in Article 11 of the Law on Consumer Protection No. 6502
  - a- Customer can use one of his/her rights to, Withdrawing from the contract,
  - b- Request a discount from the sales price,
  - c- Ask for a free repair,
  - d- Request the replacement of the sold item with a non-defective one.
- 4) If the consumer chooses the right to free repair from these rights, the wrapper; is obliged to repair or have the goods repaired without any charge under any other name, such as workmanship cost, replacement part cost or any other name. The consumer can also use the right of free repair against the manufacturer. The seller and the manufacturer are jointly responsible for the consumer's exercise of this right.
- 5) If the consumer uses the right of free repair of the goods;
  - In cases where it fails again within the warranty period,
  - The maximum time required for repair is exceeded,
  - And it is determined by a report by the authorized service station, the seller or the manufacturer that the repair is not possible;The consumer may request from the seller a refund of the price of the goods, a reduction in the amount of the defect or, if possible, replacement of the goods with a non-defective one. The seller cannot refuse the consumer's request. In case of non-fulfillment of this request, the seller, the manufacturer and the importer are jointly and severally liable.
- 6) The repair time of the goods cannot exceed 30 working days. This period begins on the date of notification of the malfunction of the product to the authorized service station or seller during the warranty period and from the date of delivery of the product to the authorized service station outside the warranty period. If the failure of the goods cannot be fixed within 15 working days, the manufacturer must allocate another product with similar characteristics for the use of the consumer until the repair of the goods is completed. In case of malfunction of the product within the warranty period, the period of repair is added to the warranty period.
- 7) Malfunctions caused by the use of the product contrary to the considerations contained in the user manual are outside the scope of the warranty.
- 8) The Consumer may apply to the Consumer Arbitration Committee or Consumer Court at the place where the settlement is located or where the consumer transaction is made in case of disputes that may arise regarding the exercise of his/her rights arising from the warranty.
- 9) In the event that this Warranty Document is not issued by the Seller, the consumer may contact the General Directorate of Consumer Protection and Market Supervision of the Ministry of Customs and Trade.

### WARRANTY CERTIFICATE

BRAND/ TITLE : RADYAL ISITMA SİSTEMLERİ A.Ş.

ADDRESS : Pelitli Mh. Şantiye Cd. No:20/B İç Kapı No:3 Gebze/KOCAELİ

PHONE : +90 850 308 08 08

E-MAIL : [info@radyal.com](mailto:info@radyal.com)

DELIVERY TIME : 2 YEARS

MAXIMUM REPAR TIME: 30 DAYS



RADYAL ISITMA SİSTEMLERİ A.Ş.  
Libadiye Cumhuriyet Mah.  
Şair Mehmet Akif Ersoy Cad.  
No: 42 Üsküdar - İSTANBUL  
Anadolu Kurumlar V.D.: 734 073 6661

DATE, SEAL AND SIGNATURE

DOCUMENT NO	ÜR/T/22
REVISION DATE/NO	08/05/2023 REV.0
EFFECTIVE DATE	09/05/2023